

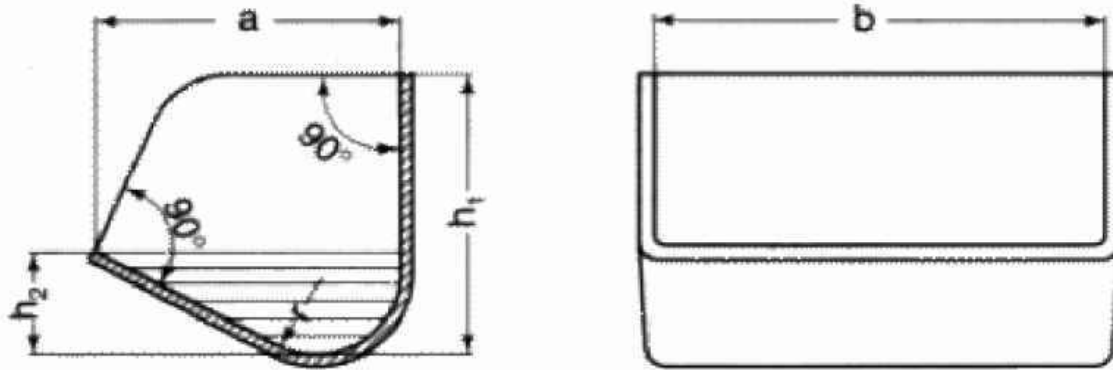

DIN 15231



Abmessungen										
b mm	a mm	h ₁ mm	h ₂ mm	Kap. in Liter	max. b /m	Löcher		Gewicht per Becher (mm)		
						d	e	1	1,5	2,0
80	75	67	24	0,10	8	8	43	0,17		
90	80	70	26	0,13	7	8	48,5	0,21		
100	90	80	28	0,16	6,5	8	55	0,26	0,39	
110	95	85	30	0,21	6	8	64	0,29	0,43	
125	106	95	34	0,28	5,5	8,5	75	0,36	0,55	
140	115	105	36	0,38	5	8,5	86	0,45	0,67	0,90
150	120	110	38	0,44	4,5	8,5	90	0,49	0,73	0,98
160	125	112	40	0,50	4,5	8,5	101	0,53	0,80	1,07
180	135	120	42	0,65	4,5	10,5	125	0,67	1,00	1,34
200	140	125	45	0,80	4	10,5	125	0,77	1,15	1,54
220	150	132	48	0,98	4	10,5	2 x 70	0,96	1,44	1,92
250	160	140	50	1,25	4	10,5	2 x 77	1,13	1,70	2,26
300	180	160	56	1,83	3,5	10,5	2 x 105		1,87	2,50
350	190	170	58	2,25	3	10,5	3 x 90		2,10	2,70
400	200	180	63	3,15	3	10,5	3 x 100		2,40	3,25
500	224	200	71	4,84	3	10,5	4 x 100			4,40

Werkstoffe: St, V2A, V4A, Aluminium

Sonderausführungen wie Randverstärkungen, Sonderlochungen und Veredlungen sind auf Wunsch möglich

